

CLEANMASTER

100-610-060

UPH 60

EXTRACTOR

120V



INFORMATION & OPERATING INSTRUCTIONS



CAUTION: DO NOT OPERATE MACHINE UNTIL YOU HAVE READ ALL SECTIONS OF THIS INSTRUCTION MANUAL

IMPROPER USE OF THE MACHINE WILL VOID THE WARRANTY

1. **NEVER USE SOLVENT IN THE MACHINE.** Use neutral pH, water-based products only!
2. Never use water with a temperature above 130 °F in the solution tank.
3. The recovery bucket should be emptied each time the holding tank is filled.
4. Always make sure the float travels freely up and down the rod after emptying the recovery bucket.
5. Always use a drop cloth under the machine during operation.
6. Vacuum any unused solution out of the solution tank and empty the recovery bucket after each job.
7. Keep machine from rain, snow, and extremes in temperatures. Store the machine in a heated location. Use the machine indoors. Do not use outdoors..
8. Do not run the pump dry.
9. Never operate a machine that is leaking or in need of repair.
10. Always use a defoamer. The vacuum shut-off will not activate properly if foam is in the recovery bucket. Water damage to the vacuum motor or other components will void the warranty.

If you have any questions before you operate the machine, call your supplier for instruction.

IMPORTANT SAFETY INSTRUCTIONS

This machine is only suitable for commercial use, for example in hotels, schools, hospitals, factories, shops, and offices. This machine is not intended for normal residential housekeeping purposes.

NOTE: Read all instructions before using this machine.

When using any electrical appliance, basic precautions should always be followed, including the following warnings and cautions:

WARNING!

To reduce the risk of fire, electric shock, or injury:

- Connect to a properly grounded outlet, only.
- Do not leave the machine unattended when it is plugged in. Unplug the unit from the outlet when not in use and before servicing.
- To avoid electric shock, do not expose to rain or snow. Store and use indoors.
- Do not allow to be used as a toy. Close attention is necessary when used near children.
- Use only as described in this manual. Use only the manufacturer's recommended attachments.
- Never add water over 130° F/54° C to the solution tank.
- Do not use with a damaged cord or plug. If the machine is not working as it should, has been dropped, damaged, left outdoors, or dropped into water, return it to a service center.
- Do not pull by the cord, use the cord as a handle, close a door on the cord, or pull the cord around sharp edges or corners. Do not run the machine over the cord. Keep the cord away from heated surfaces. To unplug, grasp the plug, not the cord.
- Do not handle the plug, the cord or the machine with wet hands.
- Extension cords must be 12/3 and no longer than 50 feet. Replace the cord or unplug immediately if the ground prong becomes damaged.
- Do not put any object into openings. Do not use with any opening blocked; keep free of dust, lint, hair, and anything that may reduce air flow.
- Keep loose clothing, hair, fingers, and all parts of body away from openings and moving parts.
- Do not pick up anything that is burning or smoking, such as cigarettes, matches, or hot ashes, or any health endangering dusts. Do not use to pick up flammable or combustible liquids such as gasoline or use in areas where they may be present.
- Turn off all controls before unplugging.
- Connect to a properly grounded outlet only.
- Liquid ejected at the spray nozzle could be dangerous as a result of its temperature, pressure, or chemical content.

INSPECTION:

Carefully unpack and inspect your UPH 60 for shipping damage. Each machine is tested and inspected before shipping. Any shipping damage incurred is the responsibility of the carrier. You should notify the carrier immediately if you notice damage to the box or to the machine or parts.

CLEANING SOLUTIONS:

We recommend liquid cleaning chemicals. Powders may be used, but, unless mixed very thoroughly, powder can cause build-up in the lines, pump, valves, and quick disconnects. A pH of 5 - 10 is strongly recommended to avoid premature wear to the pump and/or seals. Accelerated wear from inappropriate chemical use is not covered by warranty.

MAINTENANCE:

For optimum performance, flush the machine with clear water at the end of each working day. Once a month, minimum, run a flushing compound through the machine to break up any mineral or chemical build-up that may have formed.

Clean the float rod each time the recovery bucket is emptied. Inspect the filters regularly and clean as needed. The vacuum filter is located under the recovery bucket. The solution filter is located at the bottom of the holding tank.

The quick disconnects and castors can be lubricated with a penetrating spray lubricant. Fine steel wool will keep the brass quick disconnects shining. An auto interior spray cleaner/protectant will work well to keep the body clean and bright.

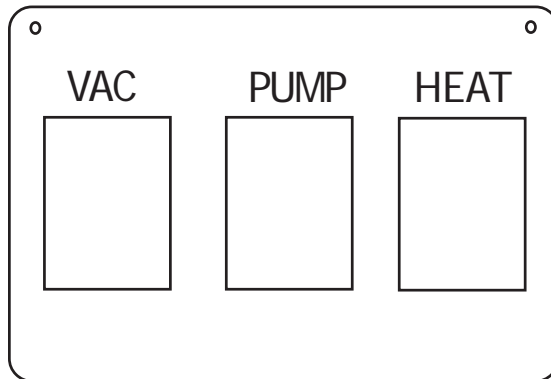

WATER HEATING:

Turn on the Heater switch. Wait two minutes for the heater to heat the water to 200+ °F.

⚠ CAUTION: Use a rag or glove to disconnect brass fittings. Fittings are very hot and may cause minor burns.

AUTO VAC SHUT-OFF:

When the recovery bucket is full, the vacuum motor will automatically shut off.

NOTE: The float will not operate properly with foam in the tank. Always use defaomer anytime foam is present to prevent damage to the vacuum motor.

DANGER: Unplug the UPH 60 from the electrical outlet before cleaning or maintaining. Certain internal components are electrically live, even with switches in their OFF position.

PARTS AND SERVICE:

Repairs, when required, should be performed by your authorized distributor who maintains an inventory of original replacement parts and accessories. Call the distributor from whom you purchased this machine if you need parts and service. Be sure to specify the machine model. Have your serial number handy.

Contact Info: CleanMaster Corporation
 11015 47th Ave. West
 Mukilteo, WA 98275
 Toll free: 1-800-426-8972
 Phone: 425-775-7272
 Fax: 425-771-7156

Serial Number: _____

Model: UPH 60

Purchase Date:_____

Write the name and phone number of your distributor:

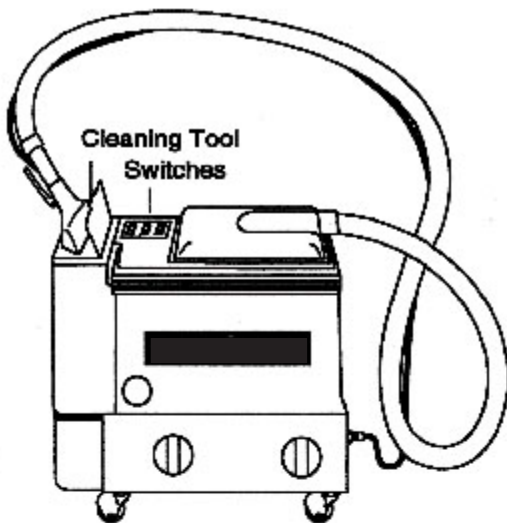

FIG. A

STEP #1

Make sure the recovery bucket under the dome is in the correct position. If the dome will not seat properly, lift off the dome, and see if the bucket needs to rotate 180 degrees. The bucket must set level; the float rod should be next to the switches.

STEP #2

Connect hoses to machine: Slide the hose cuff on one end of the vacuum hose into the hole in the dome (FIG. A). Connect the other end of the hose to your cleaning tool. Connect one end of your solution hose to the male quick disconnect on the end of the machine. Connect the other end of the hose to the tool.

STEP #3

Fill the holding tank with cleaning solution to the desired level.

NOTE: The solution must be at least 3" above the filter in the bottom of the tank.

STEP #4

Position the cleaning tool over the holding tank (FIG. A). Pull the trigger on the tool, and turn the pump switch on. When solution begins to spray, release the trigger.

STEP #5

Turn the heater switch on. Wait two minutes, and again hold the tool over the holding tank. (FIG. A) Spray for 15 seconds to heat the lines and the tool. Wait 30 seconds, then spray again for 15 seconds.

STEP #6

Turn the vacuum switch on. **NOTE:** all switches should be on now. Begin cleaning (FIG. B).

STEP #7

When the recovery bucket is full, the vacuum will turn-off. Turn off the vacuum switch. Remove the dome cover. Lift out the bucket (FIG. C), and empty it (FIG. D).

STEP #8

Dry any liquid in the bucket housing area before replacing the bucket. Make sure the float in the bucket is clean and can freely travel up the rod. Reinstall the dome lid. Begin cleaning again.



CAUTION
DO NOT LET THE PUMP RUN DRY.
ALL EXTENSION CORDS MUST BE 12/3,
AND CANNOT EXCEED 50 FT!

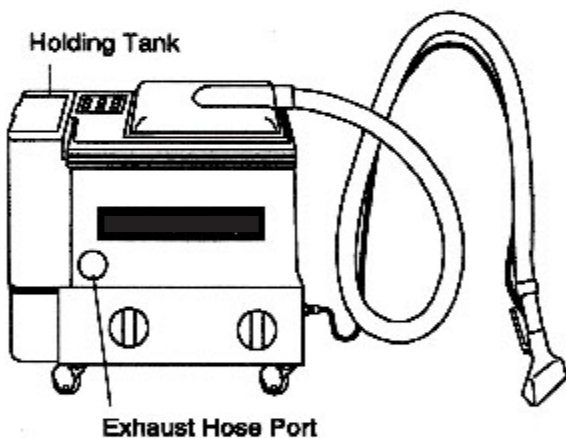

FIG. B

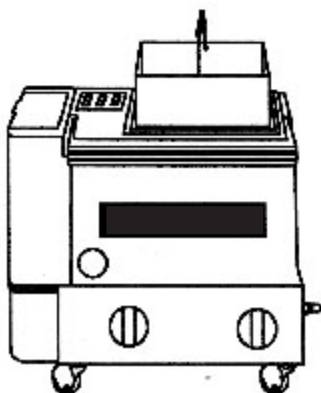
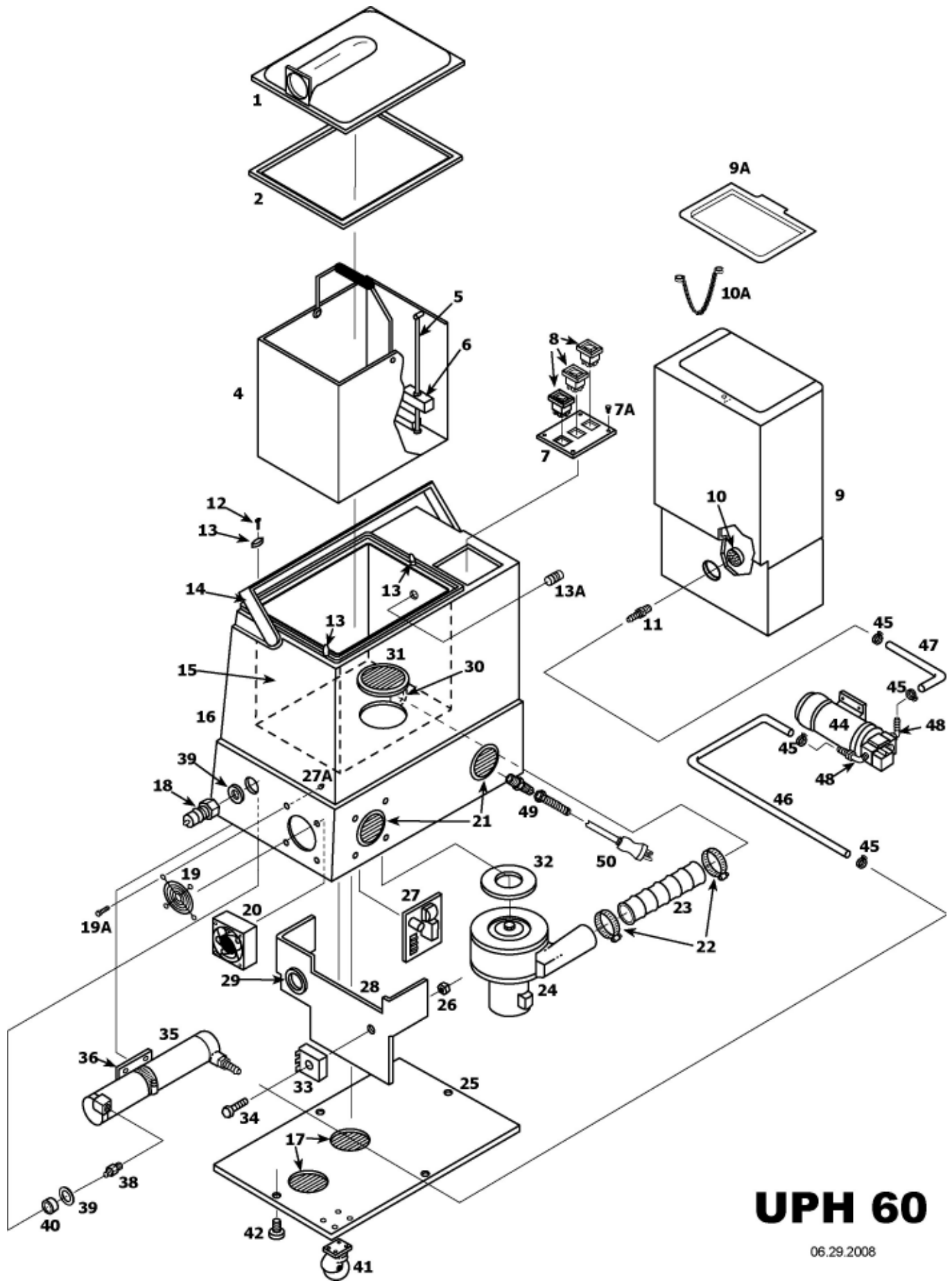

FIG. C



FIG. D

REPLACE THE PLUG END IMMEDIATELY IF ANY OF THE THREE PRONGS BECOMES DAMAGED.



UPH 60

06.29.2008

UPH 60 PARTS LIST

<u>ITEM</u>	<u>PART #</u>	<u>DESCRIPTION</u>	<u>ITEM</u>	<u>PART #</u>	<u>DESCRIPTION</u>
#1	FP368	Vacuum dome, no gasket	#24	408	Vacuum motor, 2-stage
#2	439	Gasket for dome	#25	FP137	Castor plate, complete
#4	FP147	Recovery bucket, complete	#26	8	Nut, 1/4-20
#5	421	Float rod	#27	413-1	Circuit board, heat control
#6	FP184	Float assembly	#27A	16	Nut, nylon
#7	2056	Switch plate, no switches	#28	429	Heat sink plate
#7A	28	Screw, #4 x 3/8", S/S	#29	86	Grommet
#8	FP578	Switch, rocker, with cover	#30	440	Flange, exhaust
#9	HTXLT-R	Holding tank, red	#31	FP487	Filter, vacuum inlet, 4"
#9A	2058	Lid, solution tank	#32	419	Gasket, vacuum motor
#10	207A	Filter, pump inlet	#33	409A	Relay, vacuum
#10A	805	Chain, 8"	#34	138	Bolt, 1/4" x 1-1/4"
#11	1112	Hose barb	#35	FP138A	Heat exchanger, complete
#12	19	Screw, twist-lock	#36	455	Heat exchanger, mount
#13	450	Twist-lock	#38	105	Nipple, reducer, 1/4" x 1/8 p.t.
#13A	123	Switch, reed	#39	115	Washer, fiber
#14	424	Handle, machine lift	#40	116	Washer, fiber
#15	431	Vacuum chamber	#41	418	Castor
#16	FP440	Body, black, complete	#42	29	Screw, 1/4-20 x 1/2"
#17	928	Louver, 3"(includes screws)	#44	2054	Pump, 60 psi (120V)
#18	45	Quick disconnect, 1/4 m.p.t.	#45	166	Hose clamp
#19	410	Guard, fan	#46	925	Hose, Pump outlet, 3/8" ID x 38"
#19A	2B1	Screws (Fan) 6/32" x 2-1/4, S/S	#47	FP169A	Hose, pump inlet, 3/8" ID x 14.5"
#20	412	Fan, cooling	#48	108B	Hose barb/elbow
#21	459	Louver, 2-1/2" (w/screws)	#49	184	Cord retainer
#22	156	Hose clamp, 2-1/4"	#50	495A	Power cord, 25', yellow
#23	FP163	Exhaust hose			

MISCELLANEOUS ASSEMBLIES/PARTS

FP248	Heat repair kit, includes board, cutout and probe
FP162	Dome with gasket

TROUBLE SHOOTING:

<u>IF THIS OCCURS</u>	<u>CHECK THIS</u>
NO SPRAY	Solution tank is empty, or filter is plugged up. Clogged spray tip. Pump not running. Valve on tool not operating. Solution hose not completely connected to hose or to machine.
PUMP DOES NOT RUN	This pump has a built in pressure switch, so it will only run while you are actually spraying. If the pump motor does not start running, check the wiring to the switch and to the motor. Check the switch to see if it is 'open'. If the pump is pulsating or won't stop running, the internal pressure switch may need to be adjusted. Contact your distributor for further information.
LOW SUCTION	Debris is plugging cleaning tool or vacuum hose. Drain gate is not completely closed, or seals are damaged.
NO SUCTION	Vacuum dome is not closed completely or it (or the gasket) is damaged. Float in the recovery bucket is all the way up the rod. If the tank is empty, clean the rod so the float can freely travel up and down. No power to motor. Does the switch light up? If not, the switch may be bad or there may be no power getting to the switch. Check wiring connections.
LOW HEAT	Spraying for too long will significantly drop the heat. Try spraying for 8-10 seconds, or about three strokes. Heat exchanger needs to be flushed. Wrong tool being used. Too much water passing through. Longer hose or larger diameter hose, than standard.
NO HEAT	Heat is not turned on. No power in the wall outlet - check to see if the breaker has tripped. No power to the heat switch - check wiring for 'opens'. No power out of heat switch. Replace switch. Call your distributor for additional help.

SPECIFICATIONS:

Vacuum: 80" water lift - 97 CFM

Heat Exchanger: Stainless steel coil, instant heat transfer

Pump: 60 psi diaphragm, "on-demand"

Circuit Board: Solid-state technology (sensing within 1° F)

Electrical System: 25 ft. 12/3 cord available in 120 & 240V 50/60 cycle

Weight: 43 lbs.

Dimensions: 23L x 22H x 10W

UPH 60 EXTRACTOR 120V

NOTES:

CLEANMASTER

11015 47TH Avenue West
Mukilteo, WA 98275

PH. 1-425-775-7276

www.cleanmaster.com

FAX: 1-800-426-4225